

# HIGH STREET BIN

## DESCRIPTION

A long-lasting external litter bin with tilting feature for convenient emptying and liner replacement. Robust construction with two mounting options and powder coated in any standard colour.

## BODY

2.0 mm galvanised mild steel

## LID

3.0 mm galvanised mild steel

## CAPACITY

70 litres with bag liner

## MOUNTING

Surface fixed  
In ground fixed

## OPERATION

Tilts for servicing using purpose-made locking hinge mechanism with key supplied.

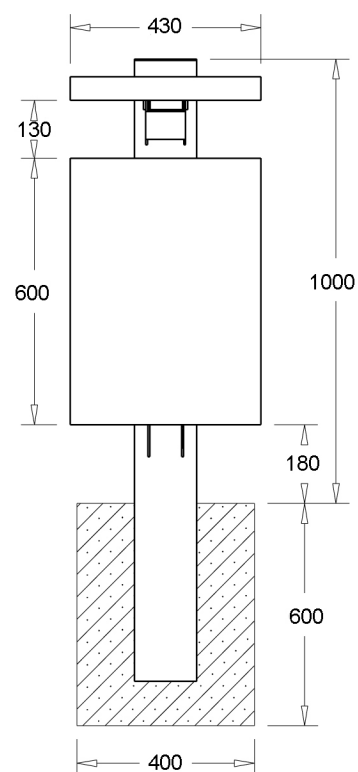

In Ground Fixed

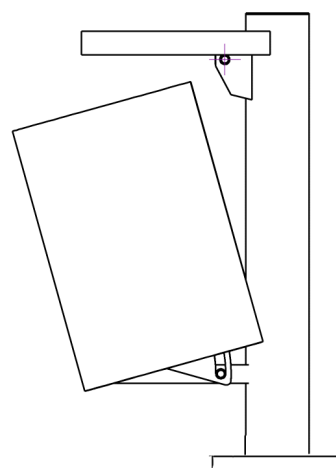

Surface fixed, showing tilt